



# ELITE LINE INTERNATIONAL CO., LTD.

6F, No. 59, Changjiang St., Chianjen Chiu, Kaohsiung 806, Taiwan R.O.C..

Tel No. : 886-7-331-1060

Fax No. : 886-7-331-0100

<http://www.watervalve.com.tw>

## The Installation of Stainless Steel Direct-Activated Pressure Sustaining / Back Pressure Valve :

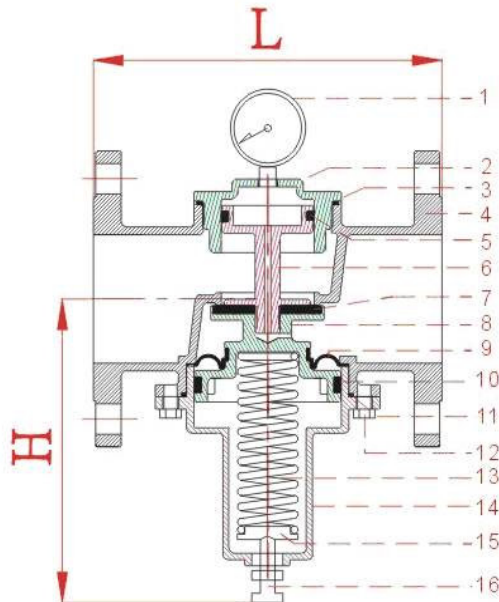

No	Part Name	Material
1	Gauge	Stainless Steel
2	Upper Cover	Stainless Steel 316
3	Washer	NBR / Viton
4	Main Body	Stainless Steel 316
5	U-ring	NBR / Viton
6	Shaft	Stainless Steel 316
7	Sealing Spacer	NBR / Viton / Teflon
8	Seat	Stainless Steel 316
9	Diaphragm	NBR / Viton
10	UH-ring	Stainless Steel 316
11	Washer	NBR / Viton
12	Fixed Bolt	Stainless Steel 304
13	Spring	Spring Steel
14	Lower Cover	Stainless Steel 316
15	Washer	Brass
16	Adjusting Stem	Stainless Steel 304

The pressure gauge indicates the inlet pressure.

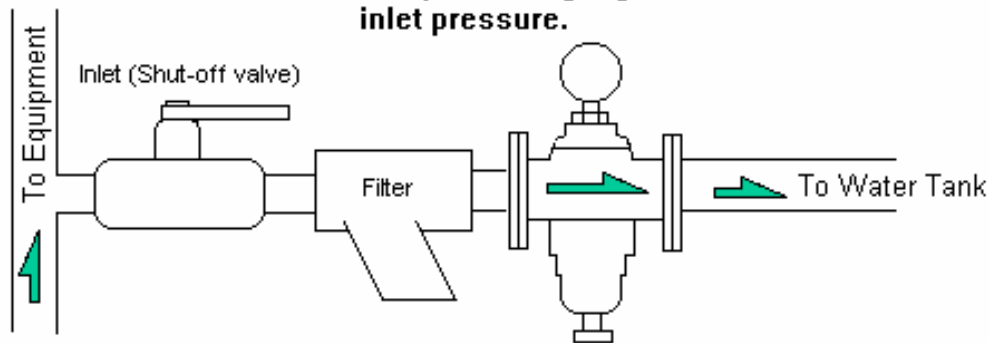

### Before Installation:

1. Clean & remove all the impurities inside the pipe. A filter is recommended to install.
2. Make sure the direction is correct.
3. Setting pressure gets higher by turning the adjusting stem clockwise.
4. The pressure gauge indicates the inlet pressure.

### Adjusting The Setting Pressure:

1. Turning anti-clockwise the adjusting stem to the lowest pressure.
2. Adjusting the pressure to the required setting pressure by turning clockwise the stem.
3. Tighten the nut to fix the adjusting stem.